

## aRil eco FANS OPERATION AND ASSEMBLY MANUAL

### DEAR SIR/ MADAM,

Thank you for choosing our product. We guarantee that it shall meet all your expectations. We wish you happiness with the purchased fan and its use.

### APPLICATION:

aRil eco fan can be used indoor (workshops, halls, warehouses, garages). aRil eco fans can be controlled by using the speed controllers.

### CONSTRUCTION:

aRil eco fan is constructed of:

- the inductive, asynchronous, monophasic engine, adjusted to continuous operation,
- the composite radial turbine,
- the housing made of pressed steel sheet with anti-corrosion protection.

### OPERATION:

aRil eco fans do not require frequent maintenance. They are suitable for continuous operation and depending on the working conditions of the fan, it can be carried out periodically if necessary.

### ASSEMBLY:

aRil eco fans are assembled on the wall, the ceiling or the prepared frame for round channel installation. After unpacking the fan, check the following:

- the condition of the supply cable (cuts, cracks of insulation),
- the condition of the fan housing (dents, distortions)
- the propeller shall not rub against the housing

The data on the technical label shall correspond to the specifications of the electrical system. It is recommended to check the condition of the product due to any damage caused in transport.

### NOTE!!!

Before installation, disconnect power supply in the electrical system! If there was no damage to the product, you can proceed to installation of the fan at the destination:

- prepare electrical connections,
- mount the fan in the ventilation duct, impose the ducts on both sides on the flanges ribbed in the housing,
- tighten the flexible ducts using the terminal clamp and screw driver (so as to put the band in the ribs in the housing),
- connection of the electrical system shall be carried out by qualified personnel with the permissions!

### MAINTENANCE:

In order to remove contamination from the fan:

- disconnect the fan from the grid remove the fan in the event of a serious degree of contamination,
- remove the turbine by using a screwdriver or a key,

- thoroughly wash all components with a damp cloth with small amount of detergent, taking care not to wet the engine,
  - after wiping dry all components of the fan, re-install them (the method of mounting of the propeller to the engine axis is solved by means of a spacer and a bolt, so spacer and a bolt, so that the bolt is not tightened all the way)
- install the fan in the destination place

### ENGINE MAINTENANCE:

The engine shall be subjected to periodic inspection depending on the conditions of operation, but not less frequently than once every two years. The inspection includes cleaning and visual inspection of the exterior of the engine and securities. The inspection shall be carried out by a person with the appropriate qualifications.

### ELECTRICAL CONNECTION:

Make sure that the voltage (V) and frequency (Hz) of the power supply correspond to the values indicated on the nameplate. The appliance must be able to be disconnected from the mains electricity supply after installation. It can be disconnected by making the plug accessible or by incorporating a switch in the fixed wiring that meets electrical installation standards. The appliance must be permanently connected with wiring for fixed installation. (2- or 3-core cable with a minimum cross-section of 1 mm<sup>2</sup> and maximum of 1.5 mm<sup>2</sup>). To complete the electrical connection, follow the wiring diagram depending on the model that you wish to connect (see fig. 2). No earthing connection is required, given that this is a doubly-insulated appliance (Class II). The power supply cable must be placed so that no liquid or vapour can enter the appliance along it.

### NOTE

The electrical connection must be carried out by a qualified electrician with the SEP authorisation! Before carrying out any maintenance operations or adjustments, disconnect the fan from the mains. The electrical system must include an isolating switch, in which the distance between the terminals of all poles shall be not less than 3 mm. Adequate precautions must be taken to avoid the reverse flow of gases into the room from the open chimney channel or other devices with an open flame. Do not apply aRil eco fans in the rooms containing an increased amount of moisture and as the explosion-proof fans. All the maintenance operations must be carried out after disconnecting aRil eco fan from the mains, even if the fan is not running!!! It is not allowed to approach to the fan during operation and without first having disconnected the power supply. It is not allowed to assemble aRil eco fan in a manner inconsistent with the manual or operate it if it is even partially incomplete! In the event of damage, have the device repaired by qualified service. Before starting the engine, check all screw connections.

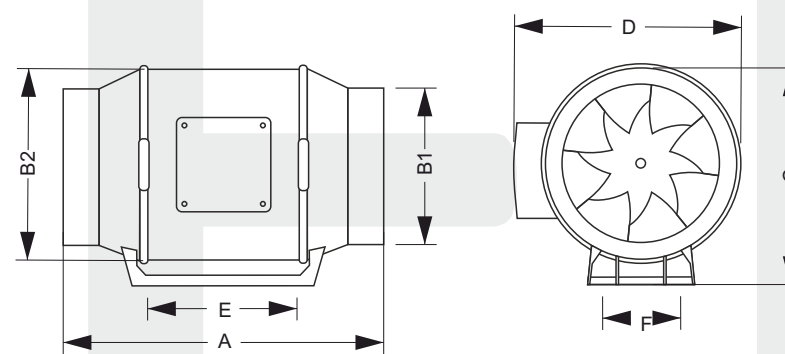
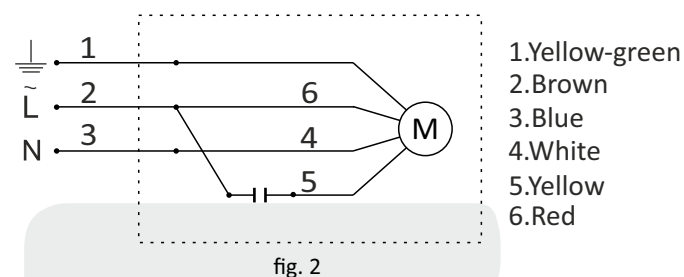

∅	A	B1	B2	C	D	E	F
75	226	72	135	155	170	49	57
100	225	95	135	155	170	49	57
125	258	122	135	155	170	58	58
150 160	310	145 155	190	210	220	60	83
200	297	198	210	230	245	80	90
250	377	245	265	280	280	135	100
310	448	295	310	330	345	195	100

### GUARANTEE

aRil eco duct fan have 2-year guarantee valid from the date of purchase. The guarantee is valid only with a proof of purchase and the properly completed guarantee card. It shall not include defects that caused by external mechanical forces activities, contaminants, own modifications, exposure to chemicals, improper assembly.

diameter		∅ 75	∅100	∅125	∅150/160	∅200	∅250	∅310
power	W	30	30	43	70	165	180	275
voltage	V/Hz	220-230V, 50 Hz						
engine rotation	1/min	2820	2770	2615	2530	2485	2650	2510
air flow	m <sup>3</sup> /h	140	210	360	560	1400	1800	2550
max. work temp		-20 ~ +50 °C						

Guarantee no: \_\_\_\_\_

Date of report	Date of repair	Scope of repair	Signature
Model: _____ Serial number: _____ Date of sale: _____ Receipt number: _____	Model: _____ Serial number: _____ Date of sale: _____ Receipt number: _____	Model: _____ Serial number: _____ Date of sale: _____ Receipt number: _____	
Seller's stamp	Seller's stamp	Seller's stamp	
Date _____ Service's stamp	Date _____ Service's stamp	Date _____ Service's stamp	

2 year guarantee

